

THE URBAN ELECTRIC C^o.



BIRGER HANG



BIRGER HANG

REGULAR

UE-2142HR

DIMENSIONS

Width	32in
Height	8.25in
Depth	32in
X	7.5in

MOUNTING

Recommended Installers	2
Weight	30lbs
Canopy	5.5in x 1.75in
Junction Box	4in oct/rnd



LAMP / WIRING

Max Wattage	(6) 60W S
Ships with complimentary LED bulbs	

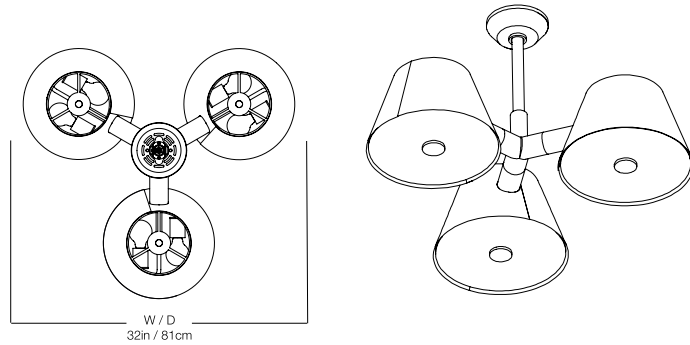
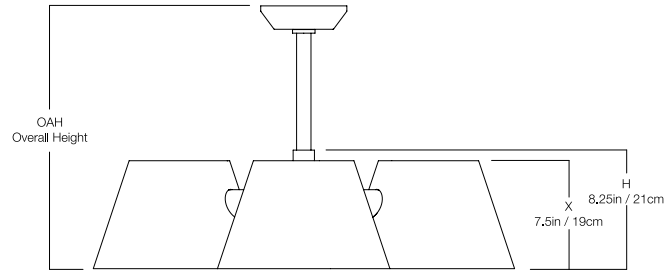

RATING

Suitable for DAMP locations



UL Listed

