

THE URBAN ELECTRIC C^o.



CHILTERN ON BRACKET WALL



CHILTERN ON BRACKET WALL

REGULAR - METAL - STANDARD HEIGHT

UE-2229WR

DIMENSIONS

Width	12in
Height	40in
Depth	13.75in
X	34in
Y	9.5in

MOUNTING

Recommended Installers	2
Weight	12lbs
Backplate	3in x 9in
Junction Box	2in x 4in rect

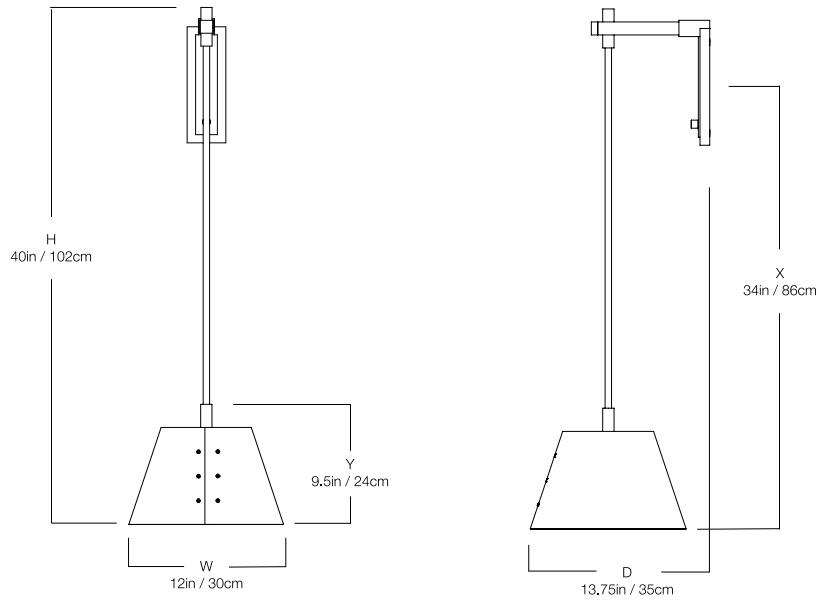
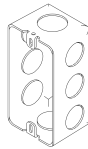

LAMP / WIRING

Max Wattage (2) 60W S
Ships with complimentary LED bulbs



RATING

Suitable for DAMP locations



UL Listed

PATENTS

This fixture has been filed with the United States Patent and Trademark Office, U.S. Pat. Pen. (U.S. Appl. No. 29/905,998)

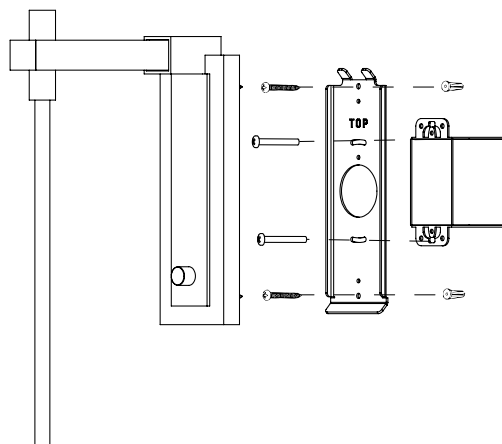

CHILTERN ON BRACKET WALL

REGULAR - METAL - REDUCED HEIGHT

UE-2227WR

DIMENSIONS

Width	12in
Height	30in
Depth	13.75in
X	24in
Y	9.5in

MOUNTING

Recommended Installers	2
Weight	12lbs
Backplate	3in x 9in
Junction Box	2in x 4in rect

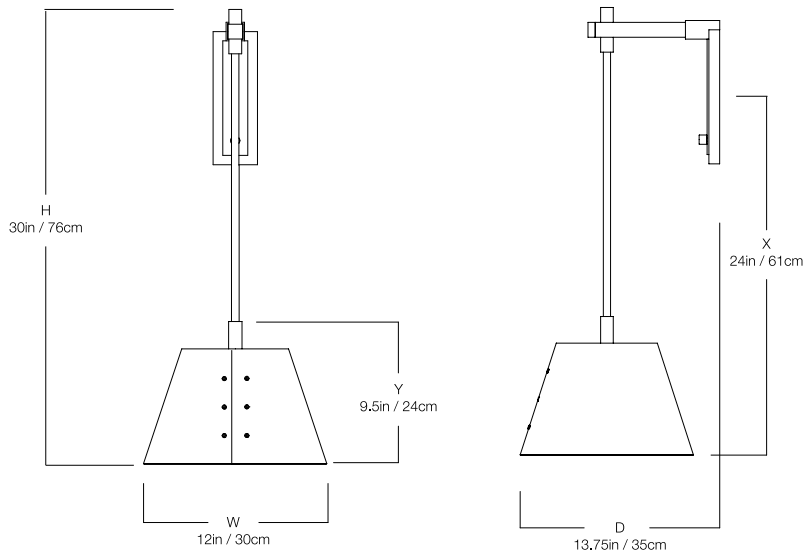
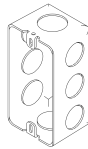

LAMP / WIRING

Max Wattage (2) 60W S
Ships with complimentary LED bulbs



RATING

Suitable for DAMP locations



UL Listed

PATENTS

This fixture has been filed with the United States Patent and Trademark Office, U.S. Pat. Pen. (U.S. Appl. No. 29/905,998)

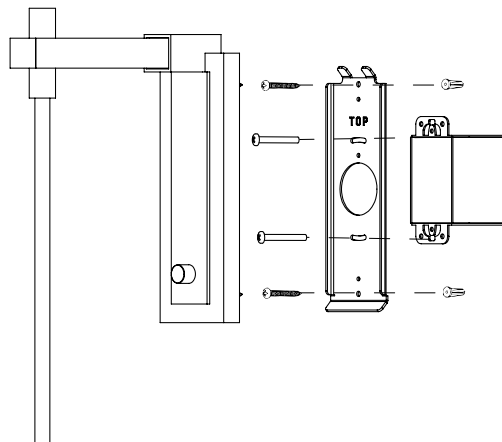

CHILTERN ON BRACKET WALL

REGULAR - METAL - MINIMUM HEIGHT

UE-2226WR

DIMENSIONS

Width	12in
Height	20in
Depth	13.75in
X	14in
Y	9.5in

MOUNTING

Recommended Installers	2
Weight	11 lbs
Backplate	3in x 9in
Junction Box	2in x 4in rect

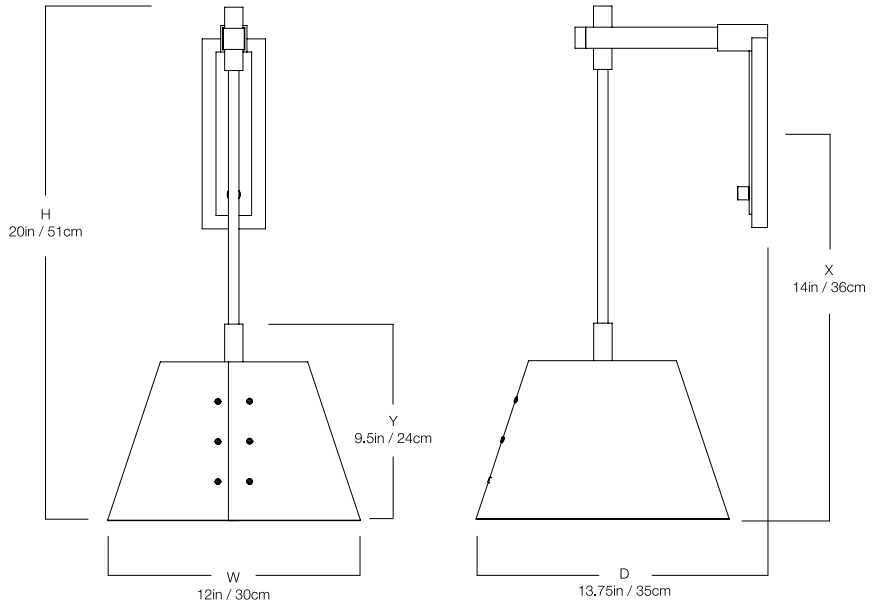
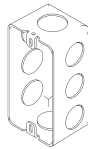

LAMP / WIRING

Max Wattage (2) 60W S
Ships with complimentary LED bulbs



RATING

Suitable for DAMP locations



UL Listed

PATENTS

This fixture has been filed with the United States Patent and Trademark Office, U.S. Pat. Pen. (U.S. Appl. No. 29/905,998)

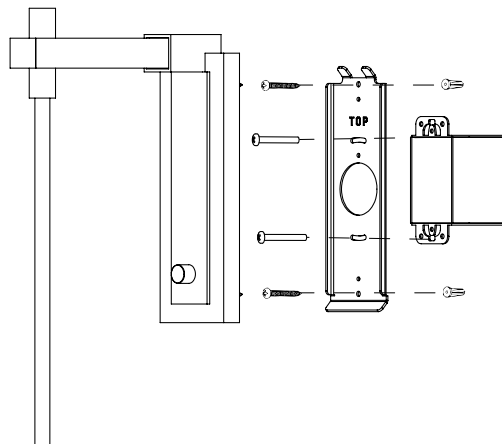

CHILTERN ON BRACKET WALL

REGULAR - FABRIC - MINIMUM HEIGHT

UE-2228WR

DIMENSIONS

Width	12in
Height	20in
Depth	13.75in
X	14in
Y	9.5in

MOUNTING

Recommended Installers	2
Weight	8lbs
Backplate	3in x 9in
Junction Box	2in x 4in rect

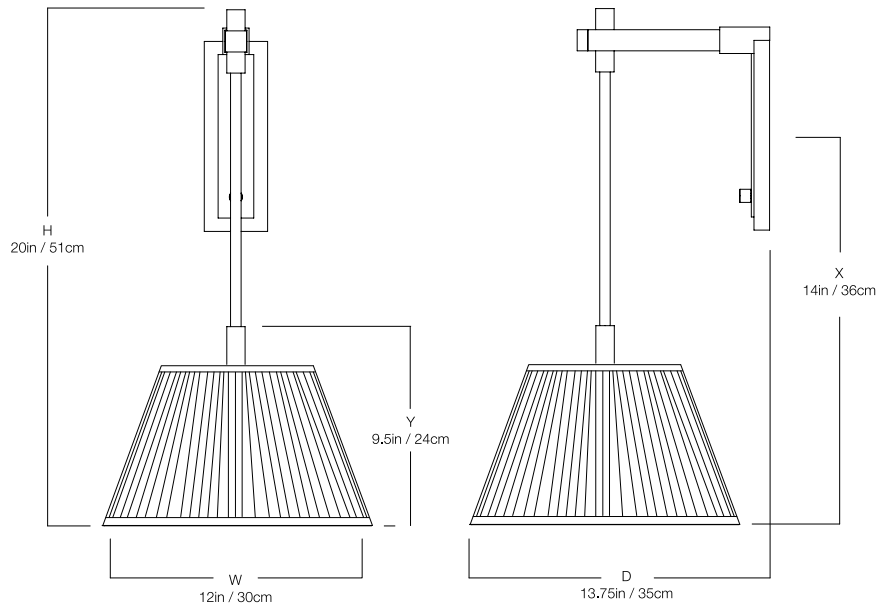

LAMP / WIRING

Max Wattage (2) 60W S
Ships with complimentary LED bulbs



RATING

Suitable for DAMP locations



UL Listed

PATENTS

This fixture has been filed with the United States Patent and Trademark Office, U.S. Pat. Pen. (U.S. Appl. No. 29/906,000)

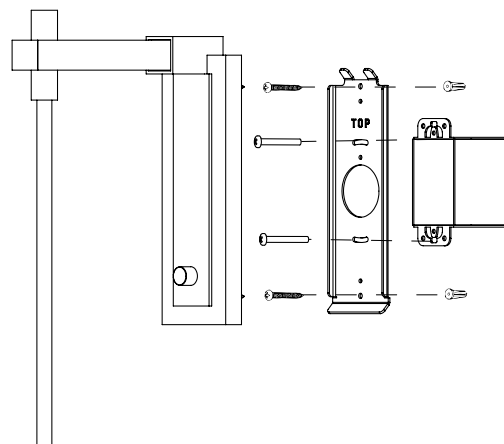

CHILTERN ON BRACKET WALL

REGULAR - FABRIC - STANDARD HEIGHT

UE-2233WR

DIMENSIONS

Width	12in
Height	40in
Depth	13.75in
X	34in
Y	9.5in

MOUNTING

Recommended Installers	2
Weight	9lbs
Backplate	3in x 9in
Junction Box	2in x 4in rect

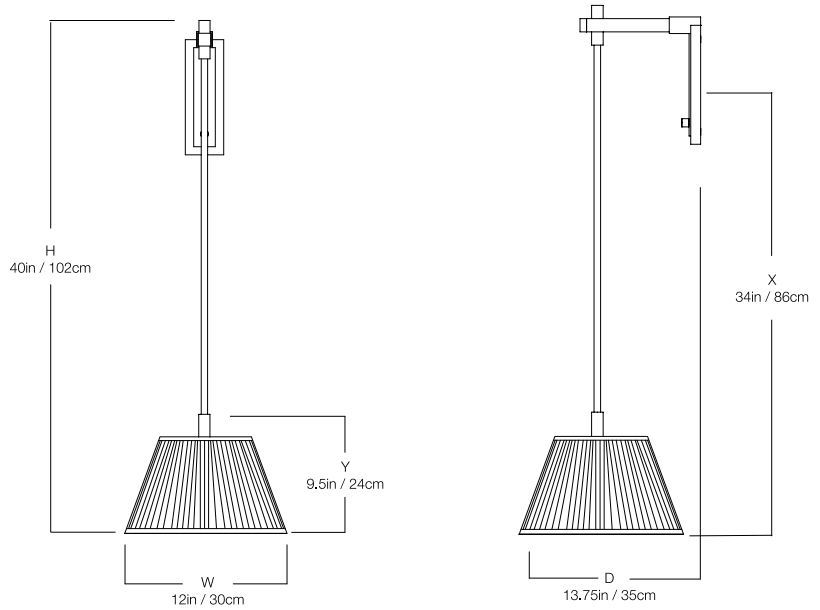
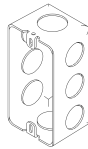

LAMP / WIRING

Max Wattage (2) 60W S
Ships with complimentary bulbs

RATING

Suitable for DAMP locations

UL Listed



PATENTS

This fixture has been filed with the United States Patent and Trademark Office, U.S. Pat. Pen. (U.S. Appl. No. 29/906,000)

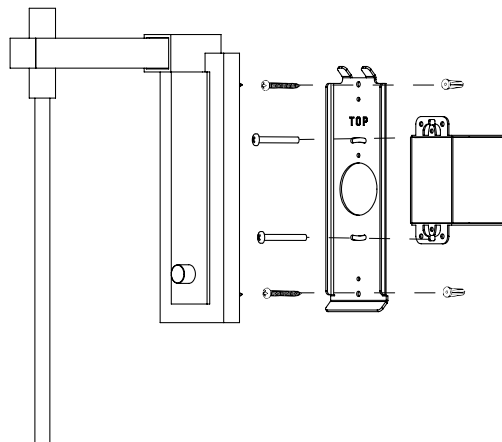

CHILTERN ON BRACKET WALL

REGULAR - FABRIC - REDUCED HEIGHT

UE-2231WR

DIMENSIONS

Width	12in
Height	30in
Depth	13.75in
X	24in
Y	9.5in

MOUNTING

Recommended Installers	2
Weight	9lbs
Backplate	3in x 9in
Junction Box	2in x 4in rect

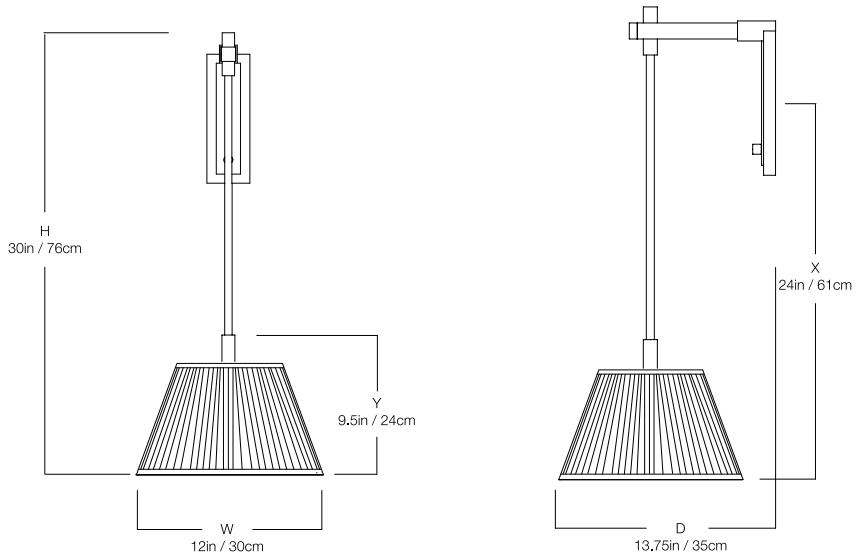
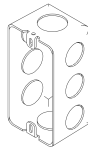

LAMP / WIRING

Max Wattage (2) 60W S
Ships with complimentary bulbs

RATING

Suitable for DAMP locations



UL Listed

PATENTS

This fixture has been filed with the United States Patent and Trademark Office, U.S. Pat. Pen. (U.S. Appl. No. 29/906,000)

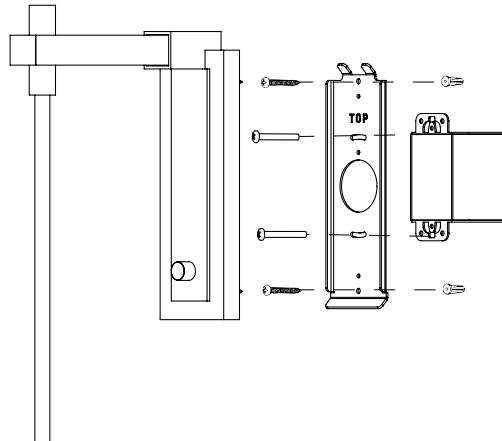

CHILTERN ON BRACKET WALL

LARGE - METAL - MINIMUM HEIGHT

UE-2226WL

DIMENSIONS

Width	16in
Height	20in
Depth	17.5in
X	4.5in
Y	11.25in

MOUNTING

Recommended Installers	2
Weight	14lbs
Backplate	3in x 9in
Junction Box	2in x 4in rect

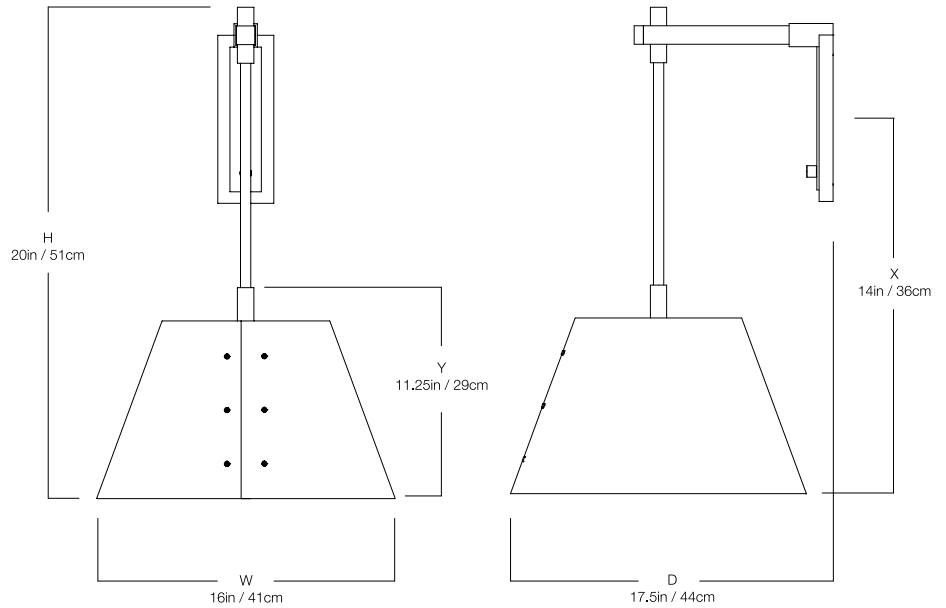
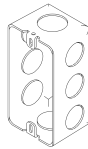

LAMP / WIRING

Max Wattage (2) 60W S
Ships with complimentary LED bulbs



RATING

Suitable for DAMP locations



UL Listed

PATENTS

This fixture has been filed with the United States Patent and Trademark Office, U.S. Pat. Pen. (U.S. Appl. No. 29/905,998)

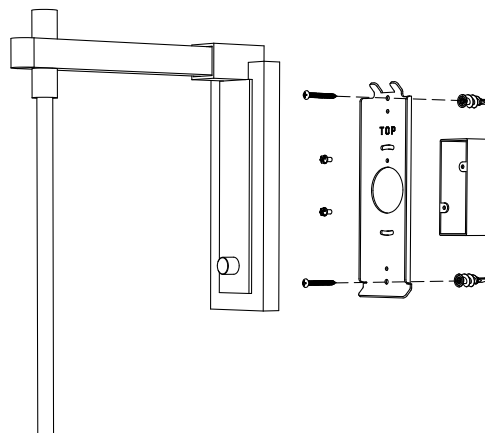

CHILTERN ON BRACKET WALL

LARGE - METAL - REDUCED HEIGHT

UE-2227WL

DIMENSIONS

Width	16in
Height	30in
Depth	17.5in
X	11.25in

MOUNTING

Recommended Installers	2
Weight	14lbs
Backplate	3in x 9in
Junction Box	

LAMP / WIRING

Max Wattage	(2) 60W S
Ships with complimentary LED bulbs	

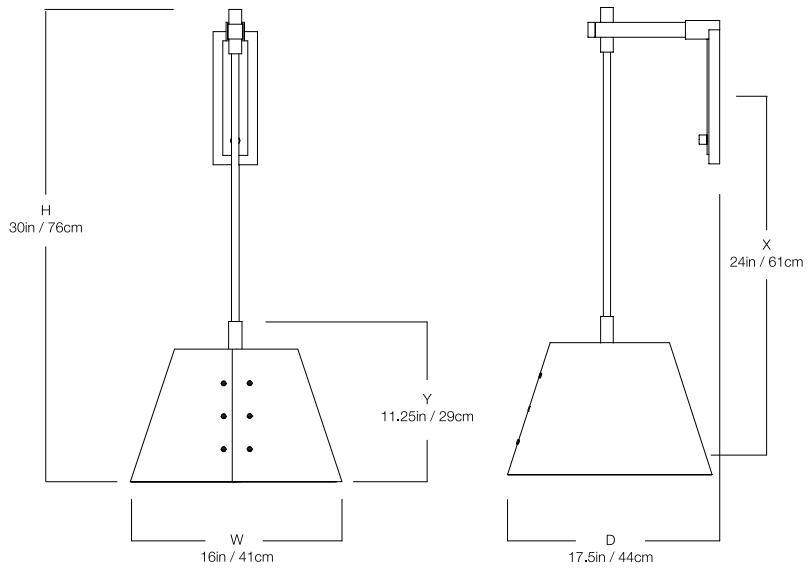

RATING

Suitable for DAMP locations



UL Listed

PATENTS

This fixture has been filed with the United States Patent and Trademark Office, U.S. Pat. Pen. (U.S. Appl. No. 29/905,998)

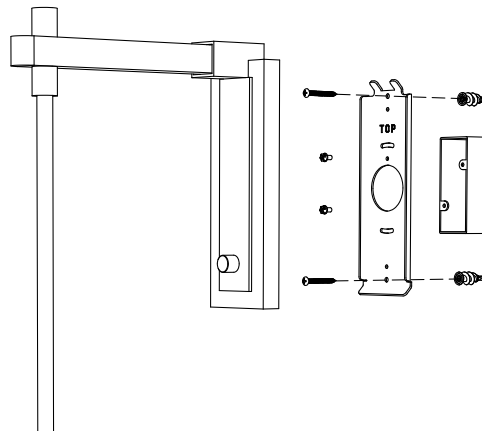

CHILTERN ON BRACKET WALL

LARGE - METAL - STANDARD HEIGHT

UE-2229WL

DIMENSIONS

Width	16in
Height	40in
Depth	17.5in
X	11.25in
Y	11.25in

MOUNTING

Recommended Installers	2
Weight	0lbs
Backplate	3in x 9in
Junction Box	2in x 4in rect

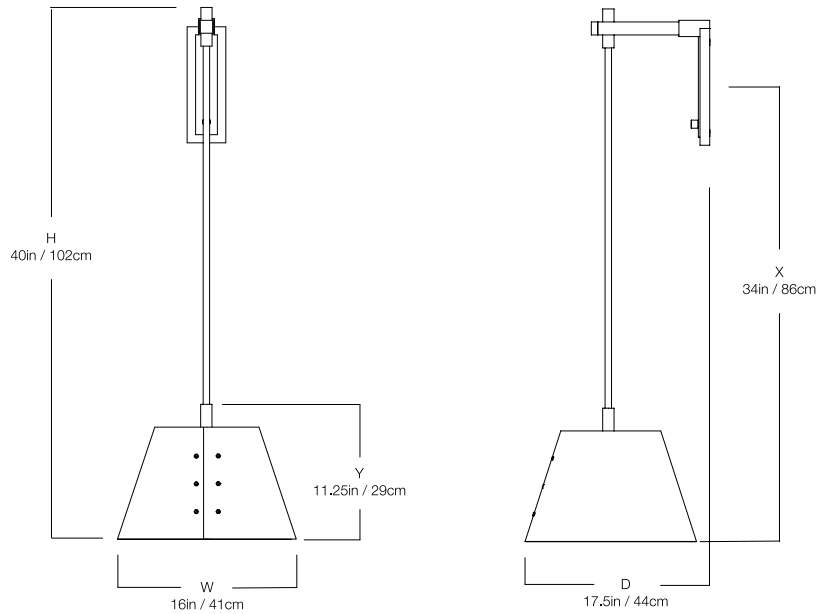
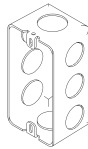

LAMP / WIRING

Max Wattage (2) 60W S
Ships with complimentary LED bulbs



RATING

Suitable for DAMP locations



UL Listed

PATENTS

This fixture has been filed with the United States Patent and Trademark Office, U.S. Pat. Pen. (U.S. Appl. No. 29/905,998)

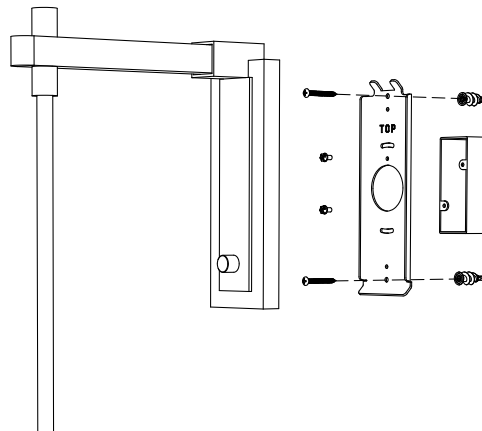

CHILTERN ON BRACKET WALL

LARGE - FABRIC - MINIMUM HEIGHT

UE-2228WL

DIMENSIONS

Width	16in
Height	20in
Depth	17.5in
X	14in
Y	11.25in

MOUNTING

Recommended Installers	2
Weight	13lbs
Backplate	3in x 9in
Junction Box	2in x 4in rect

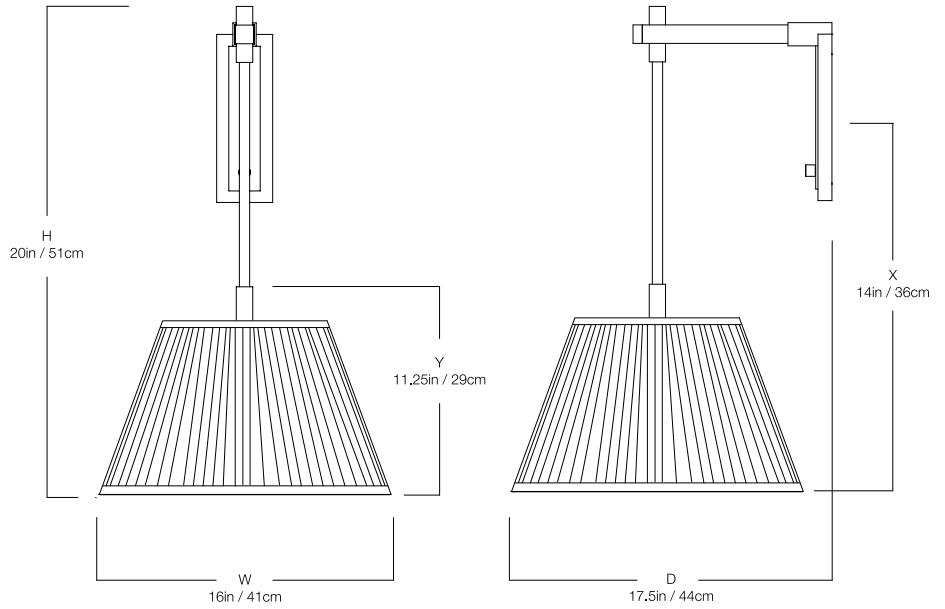
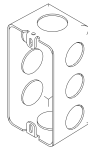

LAMP / WIRING

Max Wattage (2) 60W S
Ships with complimentary LED bulbs



RATING

Suitable for DAMP locations



UL Listed

PATENTS

This fixture has been filed with the United States Patent and Trademark Office, U.S. Pat. Pen. (U.S. Appl. No. 29/906,000)

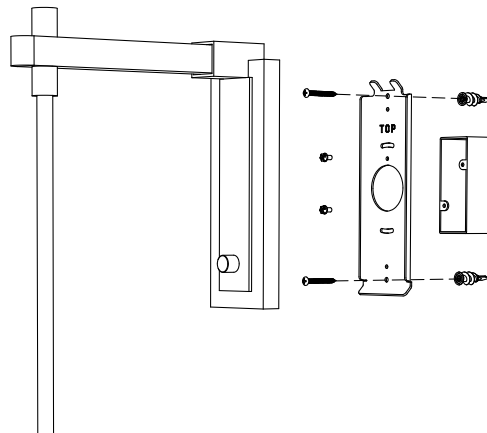

CHILTERN ON BRACKET WALL

LARGE - FABRIC - REDUCED HEIGHT

UE-2231WL

DIMENSIONS

Width	16in
Height	30in
Depth	17.5in
X	24in
Y	11.25in

MOUNTING

Recommended Installers	2
Weight	13lbs
Backplate	3in x 9in
Junction Box	2in x 4in rect

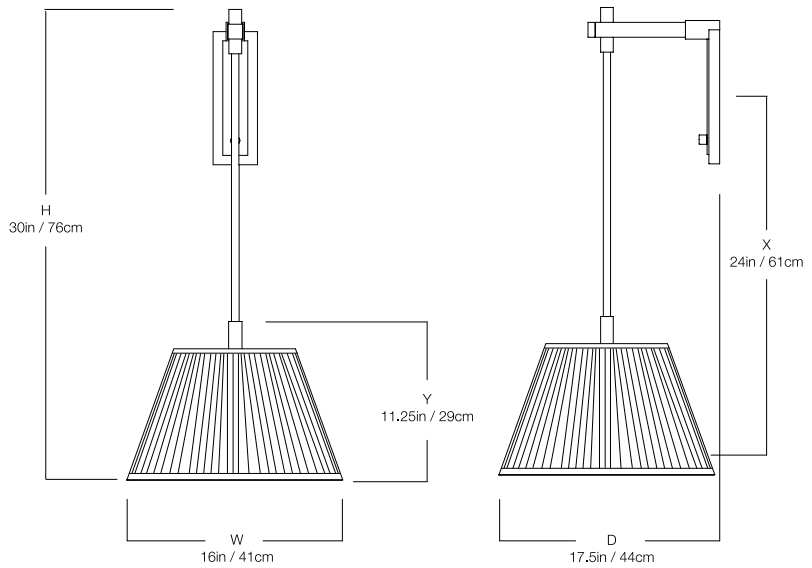
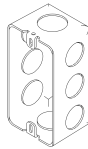

LAMP / WIRING

Max Wattage (2) 60W S
Ships with complimentary bulbs

RATING

Suitable for DAMP locations

UL Listed



PATENTS

This fixture has been filed with the United States Patent and Trademark Office, U.S. Pat. Pen. (U.S. Appl. No. 29/906,000)

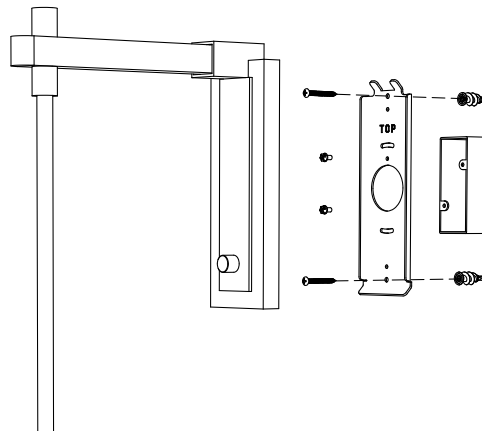

CHILTERN ON BRACKET WALL

LARGE - FABRIC - STANDARD HEIGHT

UE-2233WL

DIMENSIONS

Width	16in
Height	40in
Depth	17.5in
X	34in
Y	11.25in

MOUNTING

Recommended Installers	2
Weight	13lbs
Backplate	3in x 9in
Junction Box	2in x 4in rect

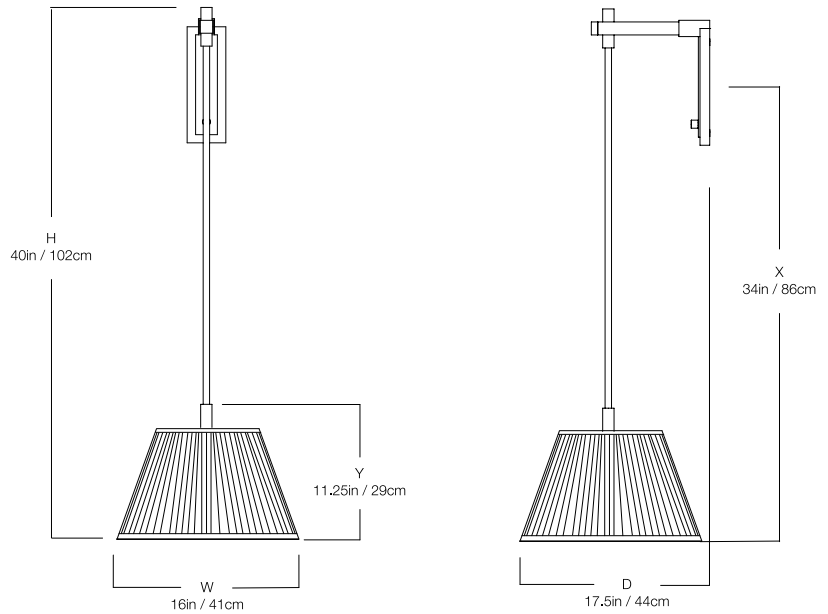
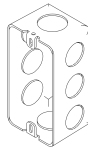

LAMP / WIRING

Max Wattage (2) 60W S
Ships with complimentary bulbs

RATING

Suitable for DAMP locations



UL Listed

PATENTS

This fixture has been filed with the United States Patent and Trademark Office, U.S. Pat. Pen. (U.S. Appl. No. 29/906,000)

