

THE URBAN ELECTRIC COMPANY



DUOMO FLUSH



# DUOMO FLUSH

HANG REGULAR

UE-2318HR

## DIMENSIONS

Width	7.5in
Height	7in
X	4.5in

## MOUNTING

Recommended Installers	1
Weight	8lbs
Canopy	6.75in x 0in
Junction Box	4in oct/rnd

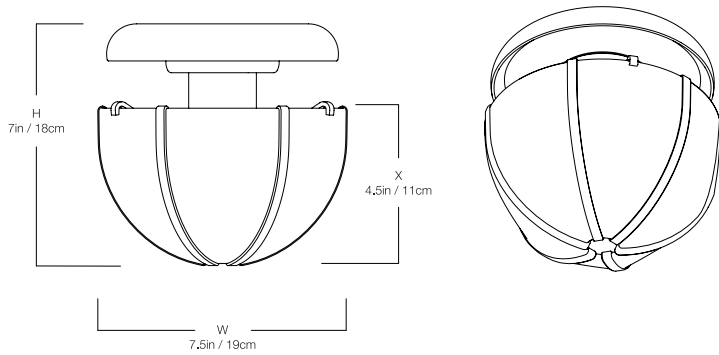

## LAMP / WIRING

Max Wattage (1) 60W S  
Ships with complimentary LED bulb



## RATING

Suitable for DAMP locations

UL Listed

