

THE URBAN ELECTRIC C^o.



GARDENER V.1



GARDENER V.1

HANG LARGE

UE-2321HL

DIMENSIONS

Width	26in
Height	18.5in

MOUNTING

Recommended Installers	2
Weight	27lbs
Canopy	8in x 0in
Junction Box	4in oct/rnd



LAMP / WIRING

Max Wattage	(1) 60W S
Ships with complimentary LED bulb	

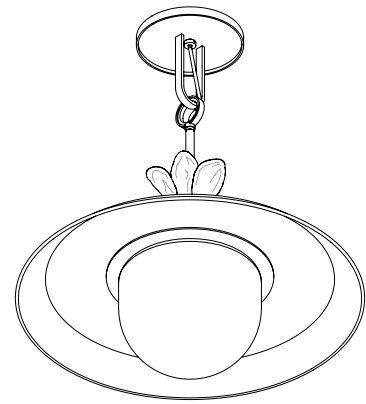
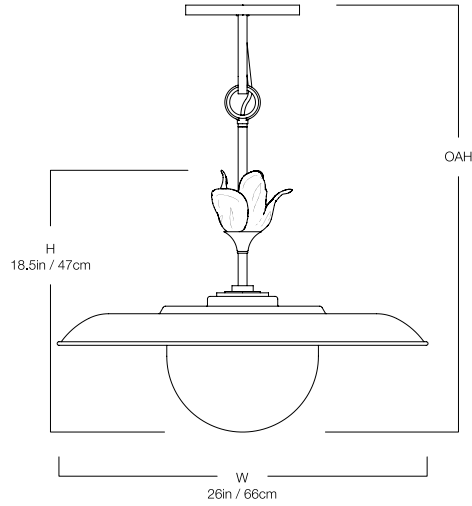

RATING

Suitable for DAMP locations



UL Listed

