

THE URBAN ELECTRIC COMPANY

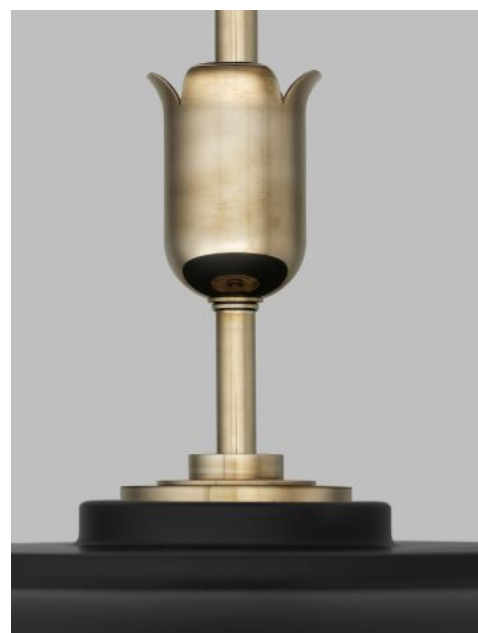

GARDENER V.2



GARDENER V.2

HANG LARGE

UE-2315HL

DIMENSIONS

Width	26in
Height	16.5in

MOUNTING

Recommended Installers	2
Weight	26lbs
Canopy	8in dia
Junction Box	4in oct/rnd



LAMP / WIRING

Max Wattage	(1) 60W S
Ships with complimentary LED bulb	

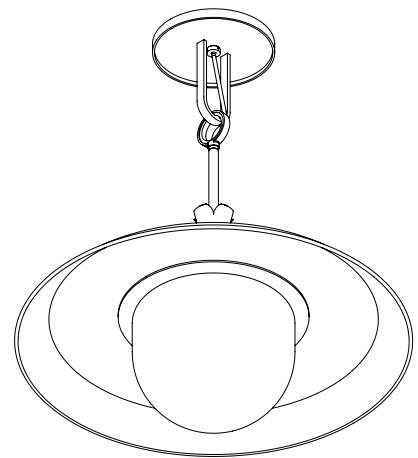
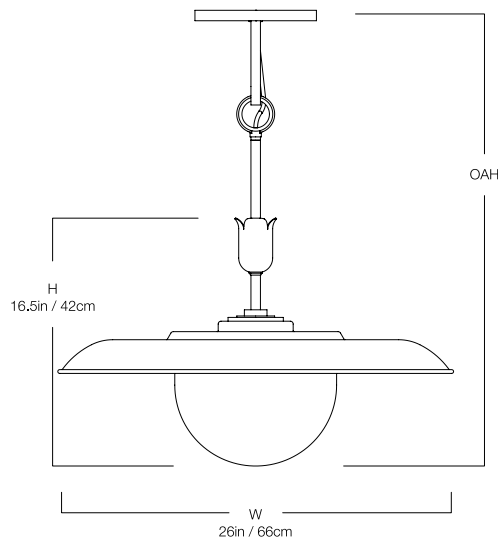

RATING

Suitable for DAMP locations



UL Listed

