

THE URBAN ELECTRIC COMPANY



MARLY



# MARLY

HANG REGULAR

UE-2260HR

## DIMENSIONS

Width	6in
Height	5.5in
Depth	6in
X	3in

## MOUNTING

Recommended Installers	2
Weight	9lbs
Canopy	6in x 0in
Junction Box	4in oct/rnd

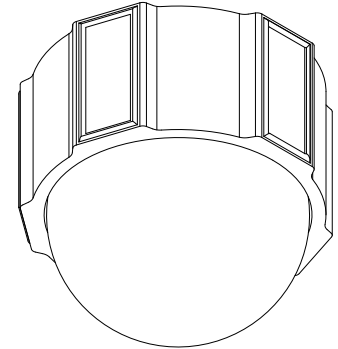
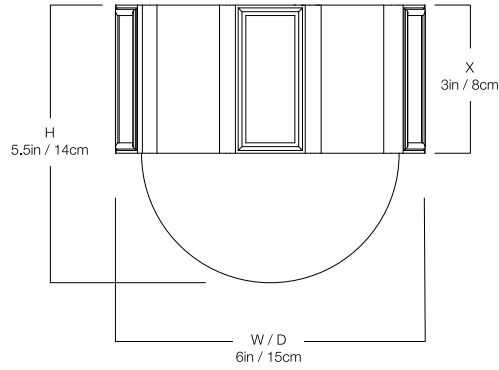

## LAMP / WIRING

Max Wattage (1) 60W S  
Ships with complimentary LED bulb



## RATING

Suitable for DAMP locations



UL Listed

