

THE URBAN ELECTRIC COMPANY

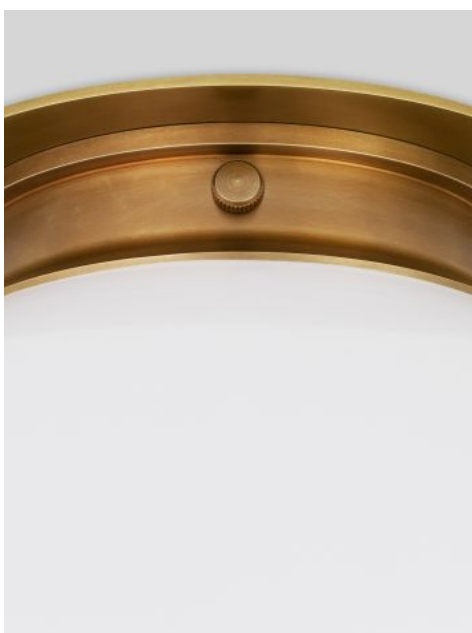

MAYFIELD FLUSH



# MAYFIELD FLUSH

HANG REGULAR

SG-2211HR

## DIMENSIONS

Width	14.5in
Height	14.5in
X	8.25in

## MOUNTING

Weight	12lbs
Canopy	8.25in dia
Junction Box	4in oct/rnd



## LAMP / WIRING

Max Wattage (1) 60W S

Ships with complimentary LED bulb

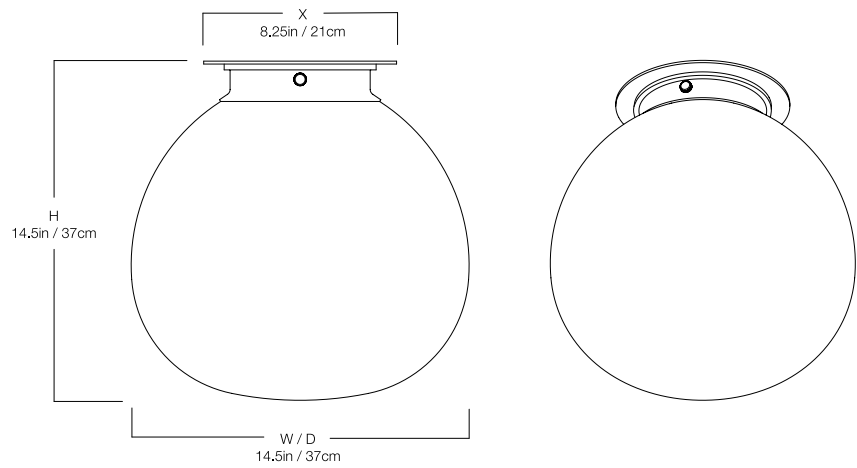

## RATING

Suitable for DAMP locations



UL Listed

