

THE URBAN ELECTRIC COMPANY



STACK



# STACK

WALL REGULAR

UE-2424WR

## DIMENSIONS

Width	8in
Height	11in
Depth	9.5in
X	2.25in

## MOUNTING

Recommended Installers	1
Weight	7lbs
Backplate	4.5in dia
Junction Box	4in oct/rnd

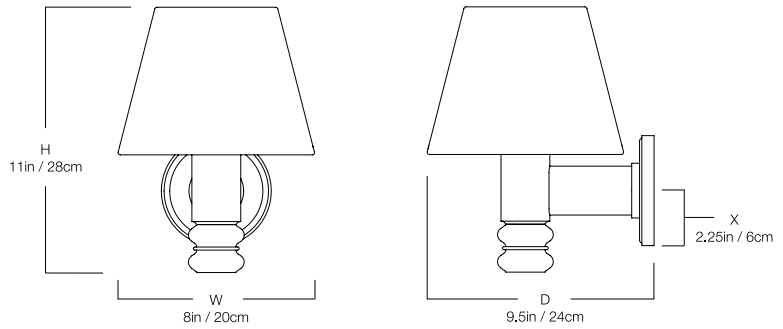

## LAMP / WIRING

Max Wattage	(1) 60W S
Ships with complimentary LED bulb	

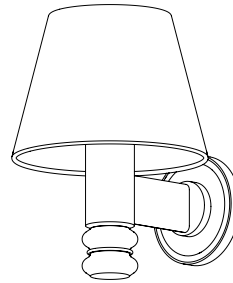

## RATING

Suitable for DAMP locations



UL Listed

