

THE URBAN ELECTRIC COMPANY



VESPER



# VESPER

HANG REGULAR

UE-2363HR

## DIMENSIONS

Width 14in  
Height 16.75in

## MOUNTING

Recommended Installers 1  
Weight 14lbs  
Canopy 10in dia  
Junction Box 4in oct/rnd



## LAMP / WIRING

Max Wattage (2) 60W S  
Ships with complimentary LED bulbs

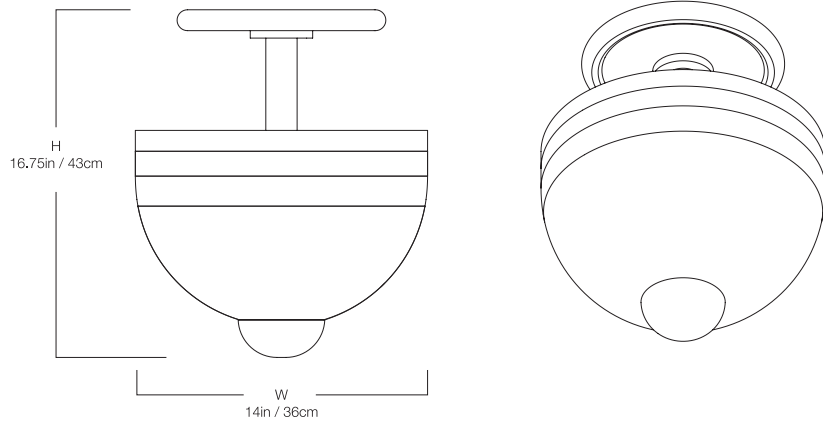

## RATING

Suitable for DAMP locations



UL Listed

